

RALLUS M

USER MANUAL



1. The luminaire shall be installed by a qualified electrician and wired in accordance with the latest IEE electrical regulations or the national requirements.
2. No supplied water-proof box, installation should be advised by qualified professional.
3. The external flexible cable can not be replaced. If the cable is damaged, the luminaire should be discarded.

! Warning:

Confirm the correct connection method, incorrect connection can lead to improper work, and even damage.

If install wrong, it may fall off.

Refer to installation instruction for installing.

I. Product Introduction:

- The fixture is LED luminaire.
- Buried installation method.
- 304#Stainless steel lamp body, High-intensity tempered glass, PMMA optical lens, Silicone water-proof sealed
- ABS buried barrel
- Ingress production is IP67
- Electrical class: Class I

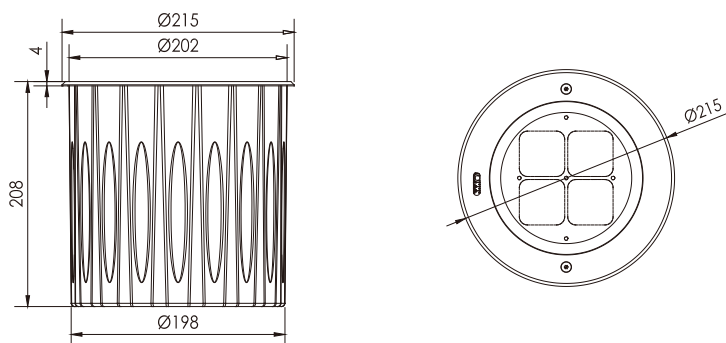

II. Technical specification:

Housing	Pressure die-cast aluminum alloy with polyester powder paint.
Front cover	Stainless steel
Glass	Tempered glass, 10.0mm-19.0mm
Housing color	Metallic
Color Temperature	3000K-5600K, RGBW
Control system	DMX-512, DALI
IK	10
PF	>0.9
IEC protection classes	I class (SELV)
Input voltage	220V
Ingress Protection Rating	IP67
Color rendering index	CRI >80
Operating temperature	-30°C ~ +50°C
Guaranteed lifetime	>70 000h

III. Observe the following dos and don'ts

1. Install in the IP 67 environment or beneath the IP67.
2. Prohibit punching any position of lamps
3. Please turn off the power and contact the dealer for problems in connection or other abnormal cases.
4. Installed by the qualified electrician holding a certificate.
5. Prohibit operating the lamps beyond the voltage scope as nation stipulated
6. Don't make the external power cable exposed during wiring.

IV. Installation Instructions

1. According to step 1, laying 20cm or much deeper water-seepage sand in the mounting hole before installing the buried barrel.
2. According to step 2, install the buried barrel.

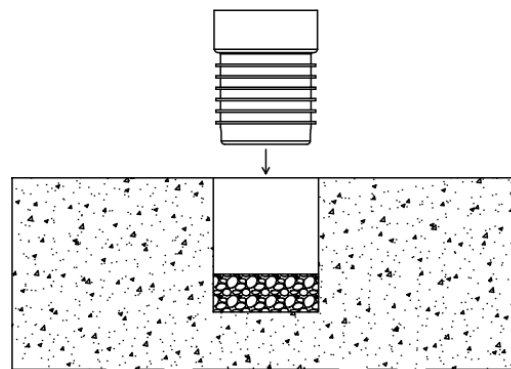

Step 2

3. According to step 3, install the lamp body of LED inground light. And fix the buried barrel and lamp body by screws.

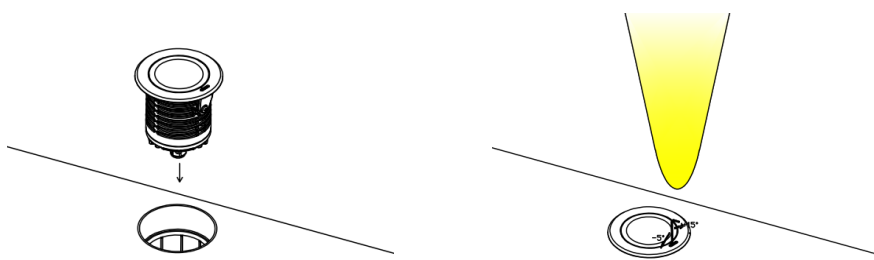

Step 3

Notes

The buried barrel must get reliable connection with the lamp body, any screws in the lamps should not be arbitrarily loosed. There is no special requirement on the installation depth.

V. Remarks for the cables.

When you get the fixture, please check and find the relative version and confirm its Color Temperature, Electrical class, the cable out.

Attention:

- When you get the fixtures is class III, please use a transformation to light.
- When you get the RGB DMX512 fixture, please accurately connect the DMX cables, otherwise, it will influence the regular work.

Cables out for different color temperature and electrical class			
v Version 1		x Version 2	
Single color v WW x CW		x RGBW (DMX-512)	
v Class I	L, N, E	Class III	Power cable: 2pin1 V+/Red wire; V-/Blue wire
Class III x DC36V x DC24V x DC12V	V+/Red wire V-/Blue wire	x DC36V x DC24V x DC12V	DMX IN cable: 3pin1 DMX+ Red wire DMX- Blue wire GND Green wire